

# NeuroML 2.0: Morphology

## Structure of NeuroML

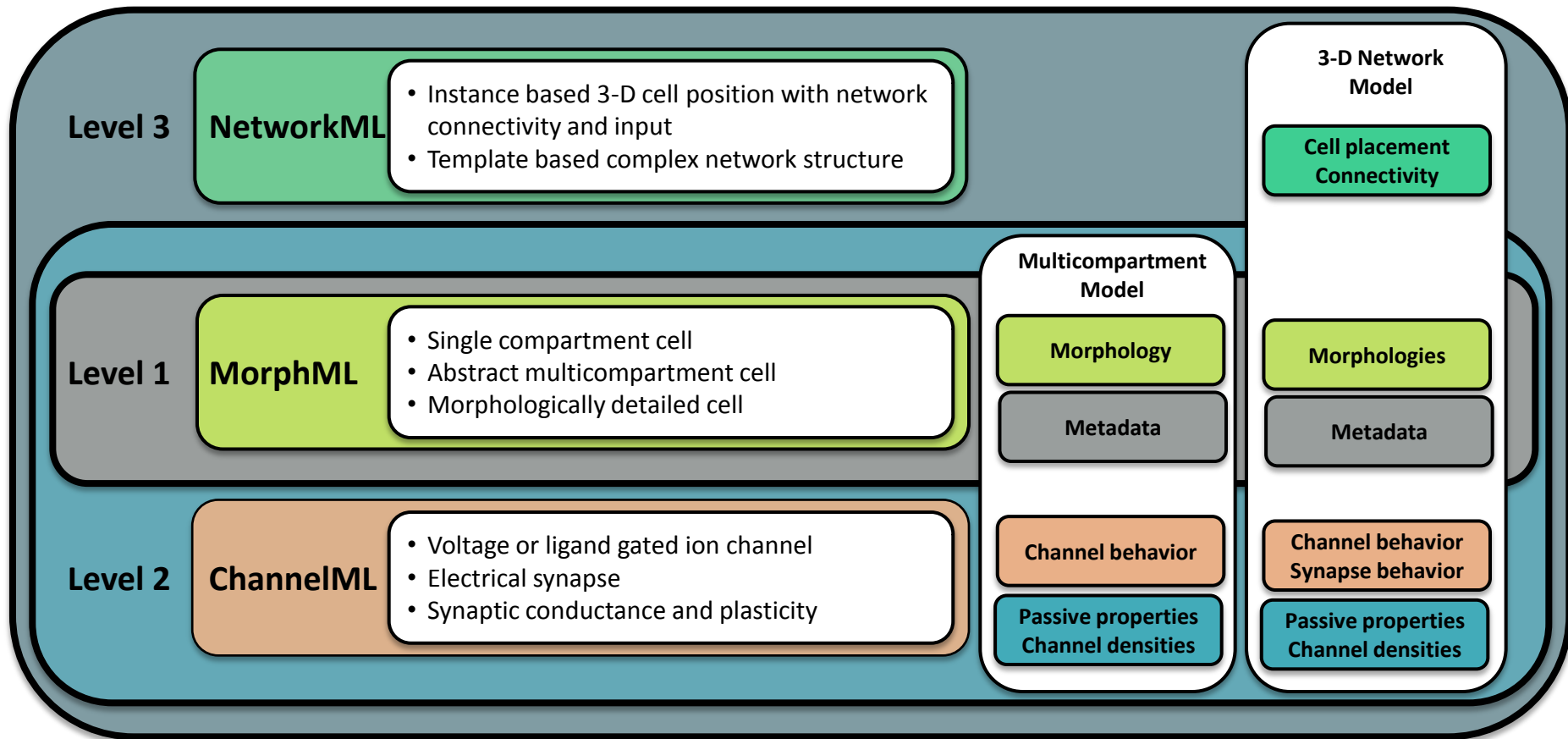



```
<segment id="0" name="Soma">    <!-- name is optional-->
  <!-- no parent => root segment -->
  <proximal x="0" y="0" z="0" diameter="10"/>
  <distal x="10" y="0" z="0" diameter="10"/>
</segment>

<segment id="1" name="MainDendrite1" >
  <parent segment="0"/>
  <!-- Same proximal 3D point as parent but different diameter -->
  <proximal x="10" y="0" z="0" diameter="3"/>
  <distal x="20" y="0" z="0" diameter="3"/>
</segment>

<segment id="2" name="MainDendrite2">
  <parent segment="1"/>
  <!-- no proximal => use distal (including diameter) of parent -->
  <distal x="30" y="0" z="0" diameter="1"/>
</segment>

<segment id="3" name="Spine" >
  <!-- Electrically connected to point 0.5 along parent -->
  <parent segment="2" fractionAlong="0.5"/>
  <proximal x="25" y="0" z="0" diameter="0.2"/>
  <distal x="25" y="1" z="0" diameter="0.2"/>
</segment>
```



```
<segmentGroup id="soma_group" neuroLexId="sa01044911821">      <!-- Reserved/special name of a group -->
  <member segment="0"/>
</segmentGroup>

<segmentGroup id="thick_dendrites">
  <member segment="1"/>
  <member segment="2"/>
</segmentGroup>

<!-- The NeuroLex reference points to the concept of a spine -->
<segmentGroup id="spines" neuroLexId="sa01145756102">
  <member segment="3"/>
</segmentGroup>

<segmentGroup id="dendrite_group" neuroLexId="sa01211023249">      <!-- Reserved/special name of a group -->
  <include segmentGroup="thick_dendrites"/>
  <include segmentGroup="spines"/>
  <!-- <exclude ...> could be present here -->
</segmentGroup>
```



<http://neuroml.org>

```
<segmentGroup id="middle">  
  <path>  
    <from segment="1"/>  
    <to segment="2"/>  
  </path>  
</segmentGroup>
```

```
<segmentGroup id="tip">  
  <subTree>  
    <from segment="1"/>  
  </subTree>  
</segmentGroup>
```



```
<cell id="SpikingCell" metaid="HippoCA1Cell">

  <notes>A Simple Spiking cell for testing purposes</notes>

  <!-- Suggestion for annotation scheme based on reference to MIRIAM resource -->
  <annotation>
    <rdf:RDF xmlns:rdf="http://www.w3.org/1999/02/22-rdf-syntax-ns#" xmlns:bqbiol="http://biomodels.net/biology-qualifiers/">
      <rdf:Description rdf:about="HippoCA1Cell">
        <bqbiol:isVersionOf>
          <rdf:Bag>
            <!-- This cell model is a version of a hippocampal CA1 pyramidal cell -->
            <rdf:li rdf:resource="urn:miriam:neurondb:258"/>
          </rdf:Bag>
        </bqbiol:isVersionOf>
      </rdf:Description>
    </rdf:RDF>
  </annotation>
```



[Back](#)

User: Public

### CA1 pyramidal neuron

Mode: [Overview](#) [Data/Search](#) [plus Connectivity](#) [plus Classical References/Notes](#) [Models](#) [BrainPharm](#)

Region: [Distal apical dendrite](#) [Middle apical dendrite](#) [Proximal apical dendrite](#) [Distal oblique dendrite](#) [Middle oblique dendrite](#) [Distal basal dendrite](#) [Middle basal dendrite](#) [Proximal basal dendrite](#) [Soma](#) [Axon hillock](#) [Axon fiber](#) [Axon terminal](#) [All Compartments](#)

Properties: [Receptors](#) [Channels](#) [Transmitters](#) [All Properties](#)

Interoperation: [Gene and Chromosome](#) [Experimental Data \(neurodatabase.org\)](#) [Microscopy Data \(CCDB\)](#)

Neuron Type: principal

Organism: Vertebrates

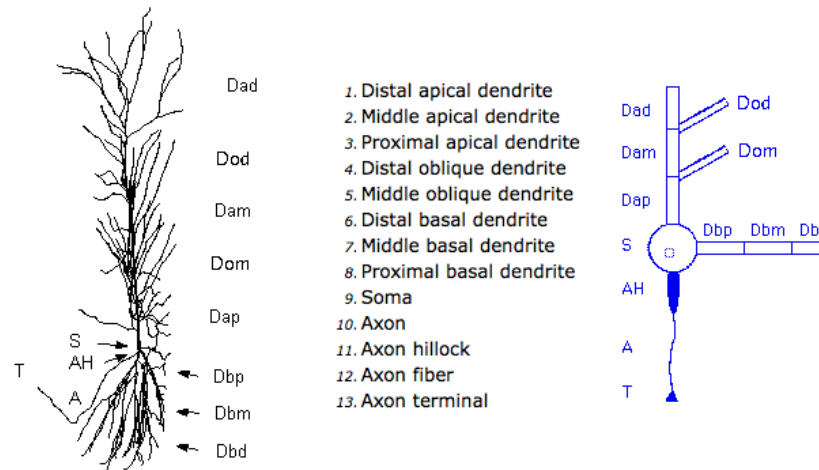

Key: Region: D, dendrite; S, soma (cell body); AH, axon hillock-initial segment of the axon; A, axon; T, axon terminal. Type of dendrite: e, equivalent cylinder (for single dendrites and multipolar trees); a, apical; b, basal; o, oblique. Level of dendrite: (p) proximal, (m) middle, and (d) distal with respect to the cell body. For further explanations, see [canonical representations](#).

Graphic from: GM Shepherd, Synaptic Organization of the Brain, New York: Oxford University Press 1978.

## Legacy Elements:

*sphere, polygon, polyhedron, path, manifold*

## Used to define:

*Features* -- fiducials or other anatomical features

*cellBody* -- detailed anatomical representation of soma for visualization

## Also:

*Spines*: based on *segment* with optional *length*, *volume* and *shape* elements

Questions?



```
<xs:complexType name="Morphology">
  <xs:annotation>
    <xs:documentation>Standalone element which is usually inside a single cell, but could be outside and
      referenced by id.</xs:documentation>
  </xs:annotation>

  <xs:complexContent>

    <xs:extension base="Standalone">

      <xs:sequence>
        <xs:element name="segment" type="Segment" maxOccurs="unbounded" />
        <xs:element name="segmentGroup" type="SegmentGroup" minOccurs="0" maxOccurs="unbounded" />
      </xs:sequence>

    </xs:extension>
  </xs:complexContent>
</xs:complexType>
```



```
<xs:complexType name="Point3DWithDiam">
  <xs:annotation>
    <xs:documentation>A 3D point with diameter.</xs:documentation>
  </xs:annotation>
  <xs:attribute name="x" type="xs:double" use="required"/>
  <xs:attribute name="y" type="xs:double" use="required"/>
  <xs:attribute name="z" type="xs:double" use="required"/>
  <xs:attribute name="diameter" type="xs:double" use="required"/>
</xs:complexType>
```



```
<xs:complexType name="Segment">
  <xs:complexContent>
    <xs:extension base="Base">

      <xs:sequence>
        <xs:element name="parent" type="SegmentParent" minOccurs="0"/>
        <xs:element name="proximal" type="Point3DWithDiam" minOccurs="0"/>
        <xs:element name="distal" type="Point3DWithDiam" minOccurs="1"/>
      </xs:sequence>

      <!-- TODO: Do we want to do away with numerical ids and just use unique strings/names in id attribute?? -->
      <!--<xs:attribute name="id" type="SegmentId" use="required"/>-->
      <xs:attribute name="name" type="xs:string" use="required"/>

    </xs:extension>
  </xs:complexContent>
</xs:complexType>

<xs:complexType name="SegmentParent">
  <xs:attribute name="segment" type="SegmentId" use="required"/>
  <xs:attribute name="fractionAlong" type="ZeroToOne" use="optional" default="1"/>
</xs:complexType>
```



```
<xs:complexType name="SegmentGroup">
  <xs:complexContent>
    <xs:extension base="Base">

      <xs:sequence>
        <xs:element name="member" type="Member" minOccurs="0" maxOccurs="unbounded"/>
        <xs:element name="include" type="Include" minOccurs="0" maxOccurs="unbounded"/>
        <xs:element name="path" type="Path" minOccurs="0" maxOccurs="unbounded"/>
        <xs:element name="subTree" type="SubTree" minOccurs="0" maxOccurs="unbounded"/>
      </xs:sequence>

    </xs:extension>
  </xs:complexContent>
</xs:complexType>
```



```
<xs:complexType name="Member">
  <xs:attribute name="segment" type="SegmentId" use="required"/>
</xs:complexType>

<xs:complexType name="Include">
  <xs:attribute name="segmentGroup" type="NmlId" use="required"/>
</xs:complexType>

<xs:complexType name="Path">
  <xs:sequence>
    <xs:element name="from" type="SegmentEndPoint" minOccurs="0"/>
    <xs:element name="to" type="SegmentEndPoint" minOccurs="0"/>
  </xs:sequence>
</xs:complexType>

<xs:complexType name="SubTree">
  <xs:choice>
    <xs:element name="from" type="SegmentEndPoint" minOccurs="0"/>
    <xs:element name="to" type="SegmentEndPoint" minOccurs="0"/>
  </xs:choice>
</xs:complexType>

<xs:complexType name="SegmentEndPoint">
  <xs:attribute name="segment" type="SegmentId" use="required"/>
</xs:complexType>
```